

ASSEMBLY INSTRUCTIONS

Before Installation:

OPEN-BOX:

1. Lay the floor mats on a flat surface to restore resilience.
2. If necessary, fold the floor mats and cargo mat in the opposite direction to restore the resilience.
3. Exposure to sunlight or application of a hair dryer can accelerate the restoration of resilience in floor mats.

RECHECK FITMENT DETAILS:

1. The floor mats are designed to fit specific vehicles.
Fitment details including but not limited to:
Make/Model/Year/Trim/Cab Style/Seat Type/
Transmission Type/Floor Type/Country of Origin
2. Unfitted floor mats may cause danger.

RETAINING HOOK:

1. If the retaining hooks are loosened, seek service from an authorized dealer.
2. Periodic check to make sure the retaining hook is secure and tight.
3. Some vehicles may not equipped retaining hook.

NOTICE:

1. Keep this instruction with the vehicle's owner manual.
2. Please inform the above safety information to all drivers of this vehicle.
3. When selling the vehicle with floor mat, please inform the next owner.

CLEAN:

1. Do not use a scrubbing brush to clean the floor mats.
2. Reinstall the floor mats after dry up.

The First Row:

1. Move the front seats to rearward position.
2. Remove any current installed floor mats from vehicle.
3. Take the floor mat, carefully install to the driver side floor and avoid accelerator and brake pedals.
4. Engage and lock the retaining hooks if equipped.
5. Install the passenger side floor mat to the passenger side floor while by pressing into position.

Note: Make sure the driver side floor mat does not interfere with the brake and accelerator pedals. If the pedals have interference with the floor mat, please remove the floor mats immediately.

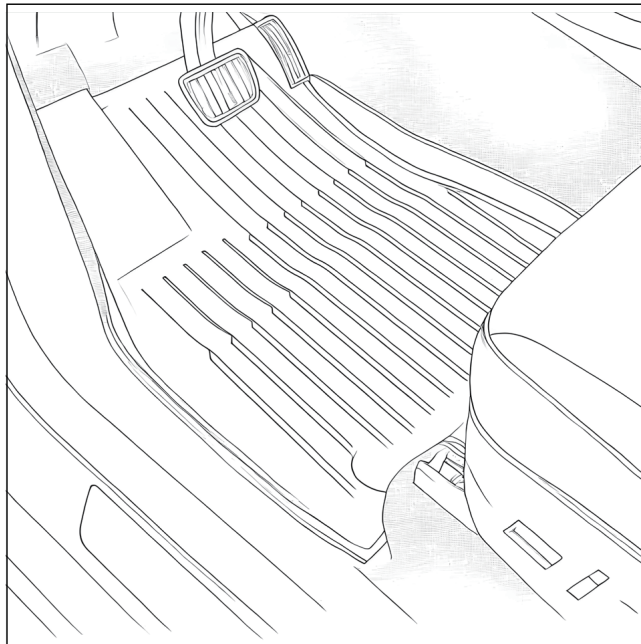

Without the Retaining Hook

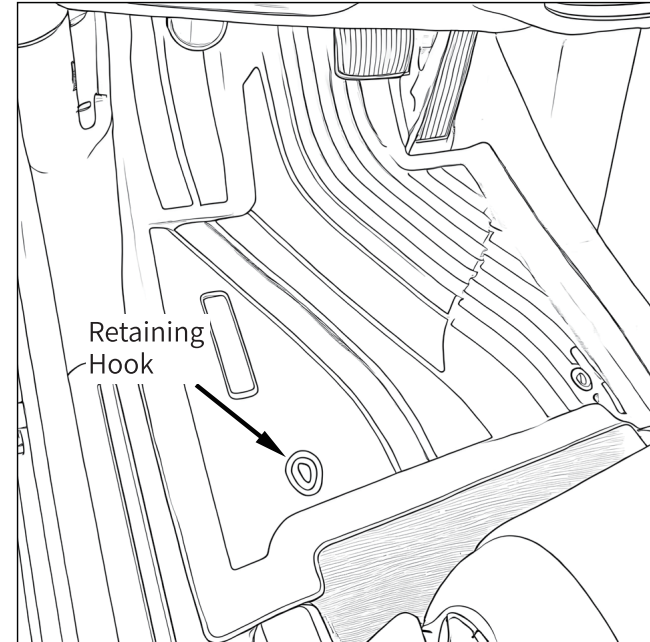

With the Retaining Hook

The Second Row:

1. Move the front seats to forward position.
2. For pickup trucks flip up the 2nd row seats.
For SUVs and MPVs move the 2nd row seats to rearward position.
3. Take the 2nd row floor mat(s) and fully install to the 2nd row floor.

Note: Refer to our listing images to verify the upside and the downside.

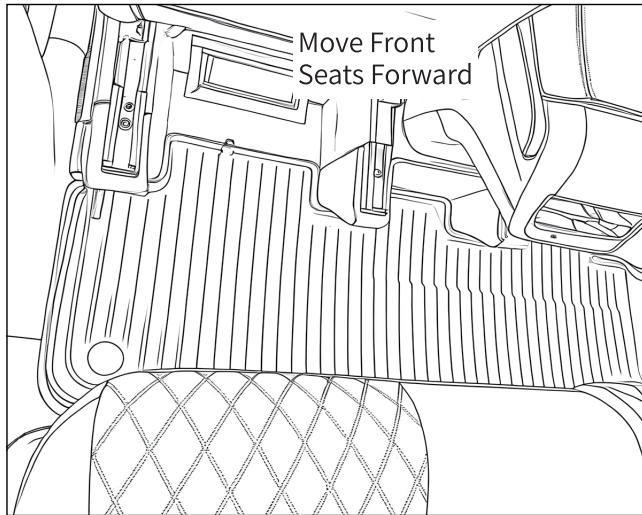

For Sedan & SUVs

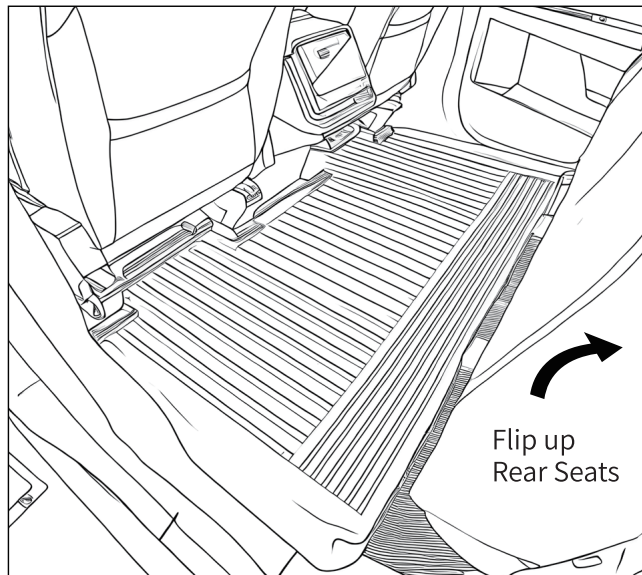

For Pickup Trucks

The Third Row (If Equipped) :

1. Move the 2nd row seats to forward position.
2. Fold down the 2nd row seats, if available.
3. Take the 3rd row floor mat(s) and fully install to the 3rd row floor.

Note: Refer to our listing images to verify the upside and the downside.

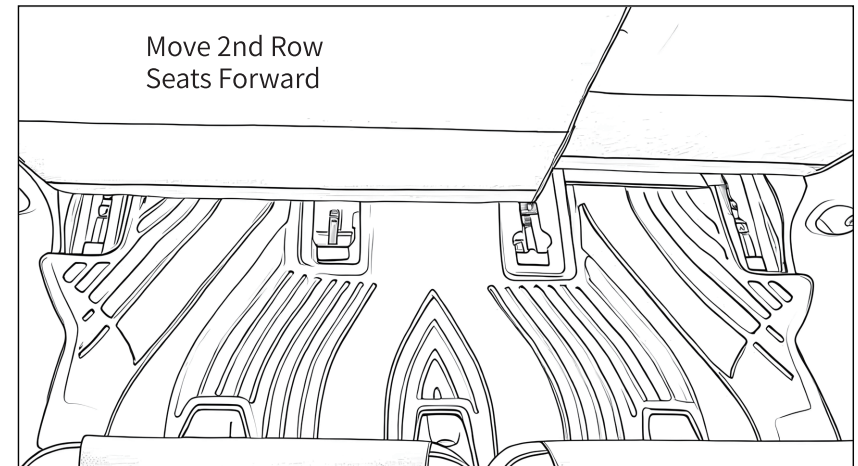

Cargo Mat (If Equipped) :

1. Custom trimming of the cargo mat may be required to accommodate stereo or other OEM components.
2. If the cargo mat includes an integrated seatback protector, then fold the rear row seats.
3. With the tailgate/trunk open, install the cargo mat in position.
4. Put some weight on center and corners of the cargo mat to keep resilience before first drive.

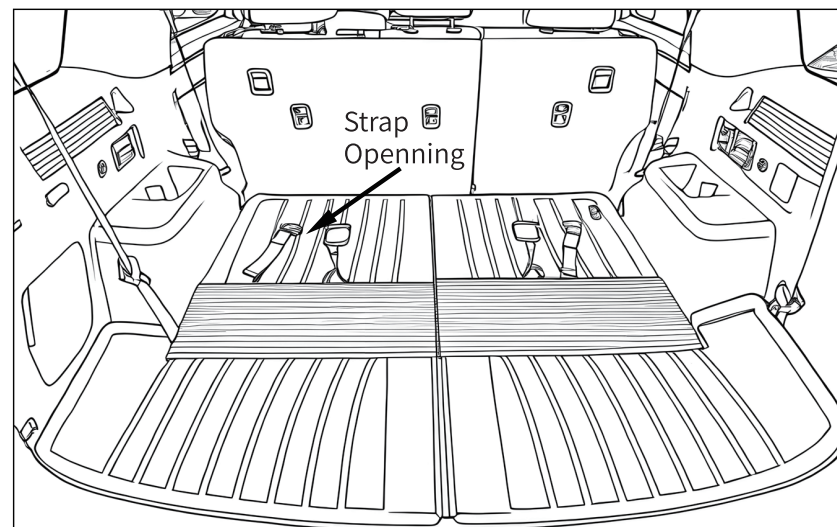
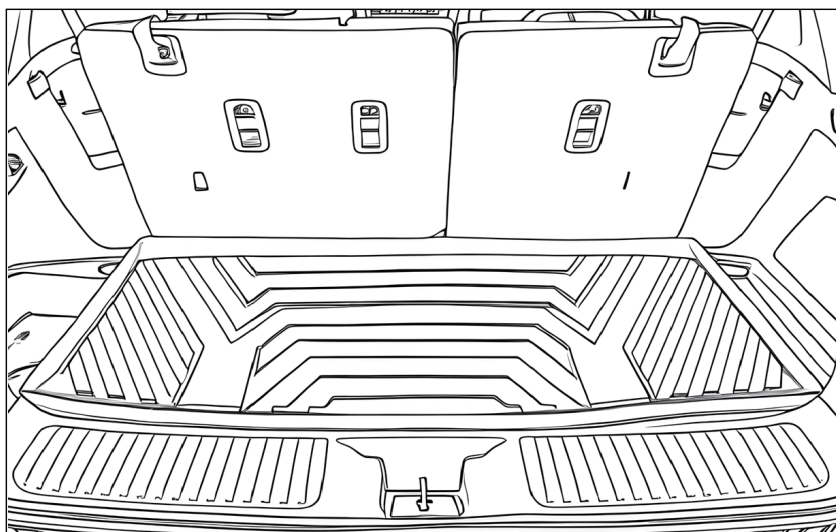

Seatback Protector (If Equipped) :

1. Fold down the rear row seats.
2. Clean the seatback felt, dust and debris may affect the firmness of the Velcro.
3. (Optional) Cut strap and securing hook openings if necessary.
4. Secure the seatback protectors.
5. (Optional) Install the loops onto head restraints and adjust to tight.

