

# ASSEMBLY INSTRUCTIONS

## Notice:

- 1.Retain for future reference,read carefully.
- 2.Professional installation would be highly recommended.
- 3.Period check to ensure all clamps remain secure and tight.
- 4.Tonneau cover must be completely secured in the closed position or opened position while driving.
- 5.Clean the debris before folding the tonneau cover.
- 6.The tonneau cover needs to be removed in extreme weather,such as typhoon,hurricane,heavy rain and hail.

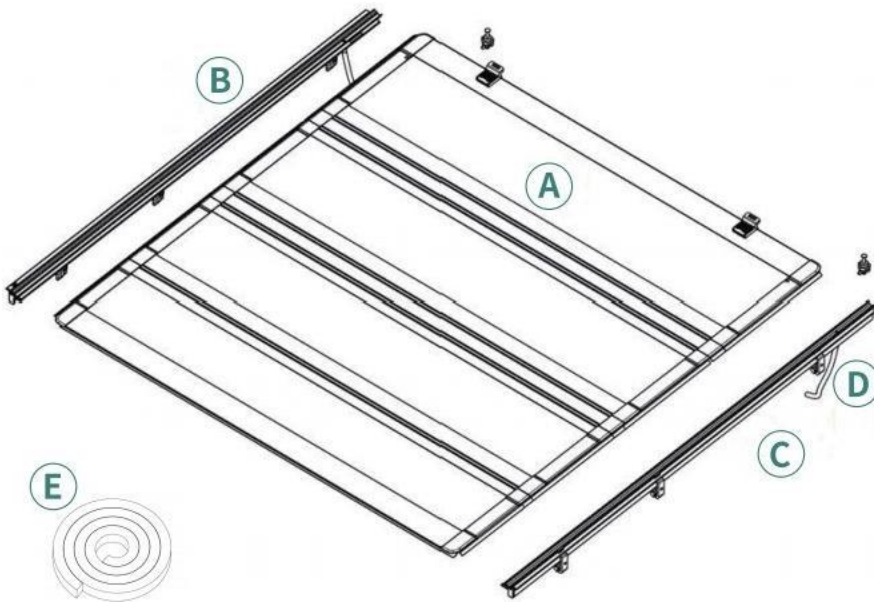

## Parts:

|   |         |         |                     |   |    |                     |
|---|---------|---------|---------------------|---|----|---------------------|
|   | 4-5.8ft | 6-6.9ft |                     | ② | ×1 | 5mm Hex Wrench      |
| A | ×1      |         | Cover Assembly      | ③ | ×1 | 4mm Hex Wrench      |
| B | ×1      | ×2      | Driver Side Rail    | ④ | ×1 | 2.5mm Hex Wrench    |
| C | ×1      | ×2      | Passenger Side Rail | ⑤ | ×2 | M8 Thread Knob      |
| D | ×2      |         | Drain Tube          | ⑥ | ×2 | M8 Thumb Nut        |
| E | ×1      |         | Front Seal Strip    | ⑦ | ×2 | M8 Cap Nut          |
| ① | ×6      | ×8      | Mounting Clamp Set2 | ⑧ | ×2 | M8×65 Carriage Bolt |

[1]Due to the limitations of the packaging,the side rails willbe divided into a long and a short section.Same as the passenger side rail.

[2]For 2015-on Colorado Canyon trucks,the rear clamps have a specific design. Trucks with utility rails require specific clamps and other components for different models. (Not available on the Ford Maverick with utility rails)

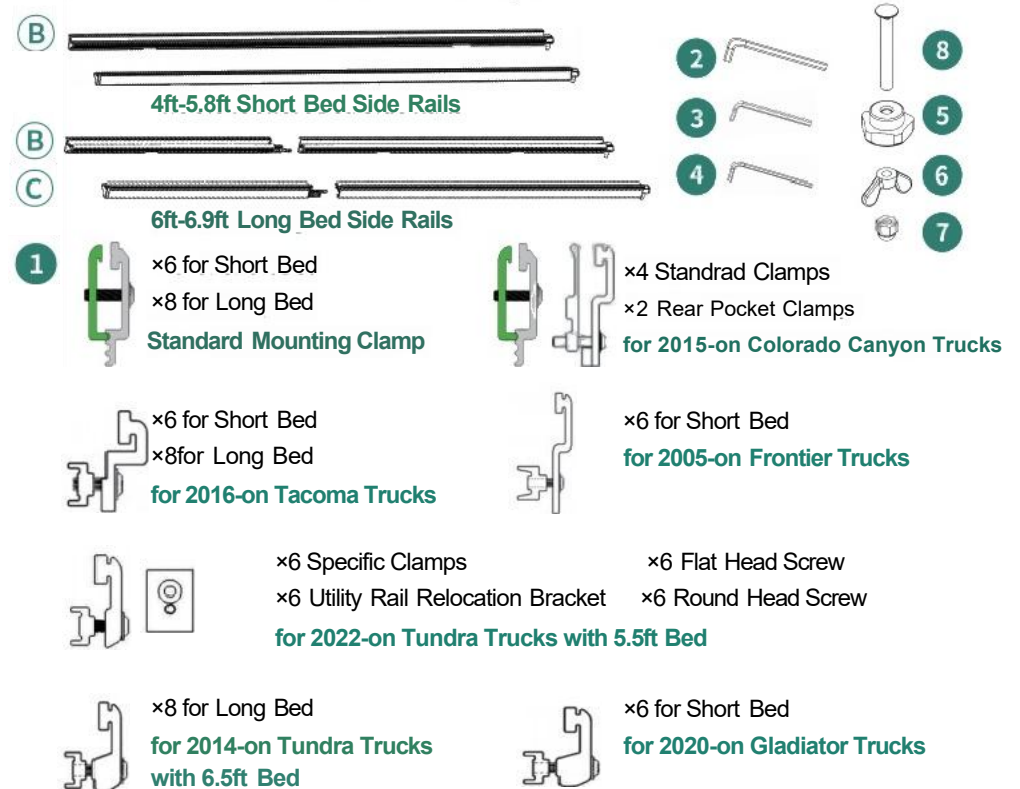

## Step 1:

1. Clean the bulkhead and bedrail before installation.
2. Stick the seal strip onto the bulkhead.

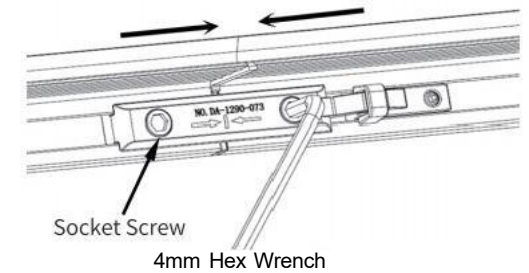
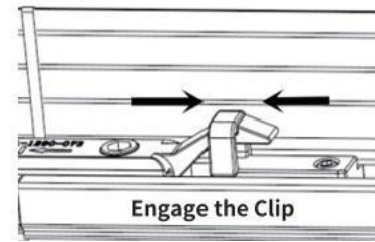
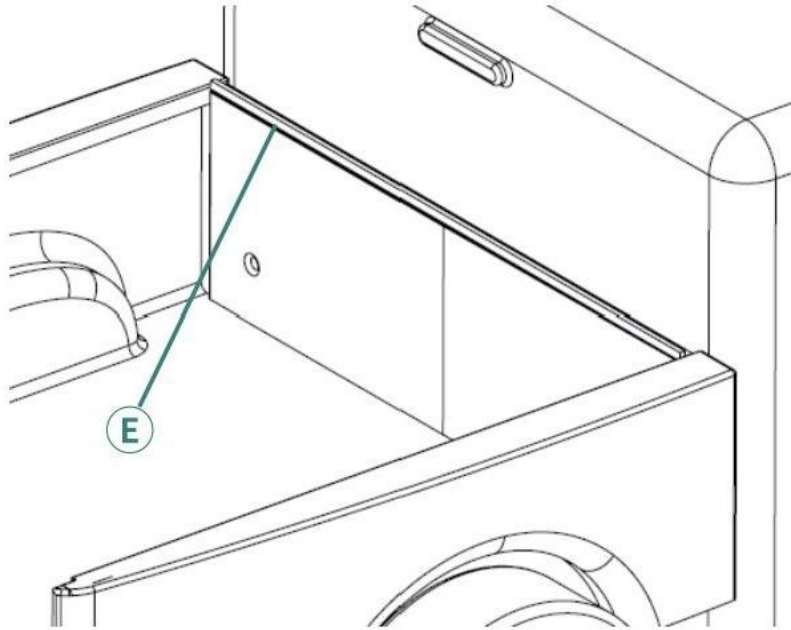

## Special Instruction for 2022-up Tundra 5.5ft:

1. Remove the factory utility rails from the truck bed wall with 4mm hex wrench.
2. Take the rail relocation brackets to factory mounting position and secure with supplied flat head screws.
3. Take the factory utility rail to rail relocation brackets and secure with supplied round head screws.

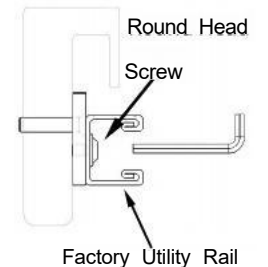
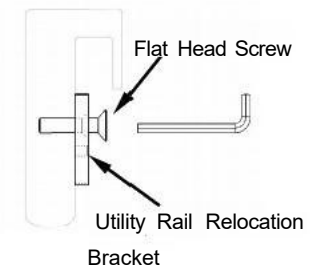
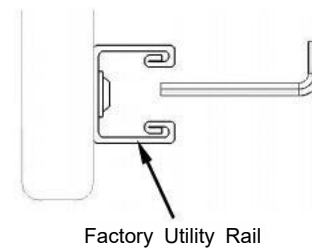

## Step 2:

1. For long bed trucks ( $\geq 6ft$ ) ONLY, connect the long and short sections of each side rails.
2. Engage the clip and tighten the socket screws with 4mm hex wrench.

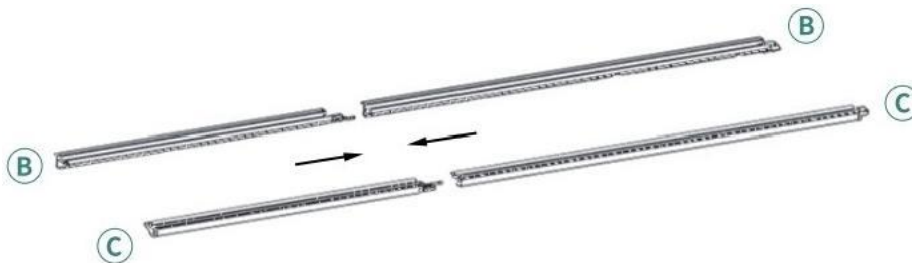

## Step 3:

1. Position the driver and passenger side rails flush against the upper and inner edges of the truck bed, ensuring the front ends align with the bulkhead.
2. Ensure the side rails are straight and tightly flush with the interior of the truck bed.
3. Aligned with the front side of the truck bed.

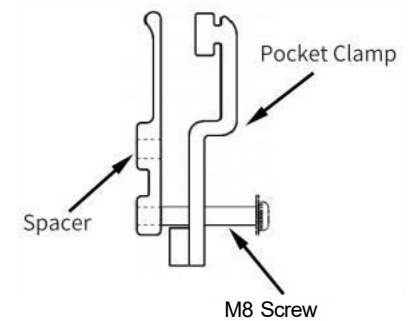
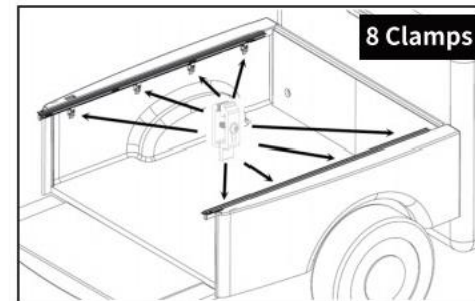
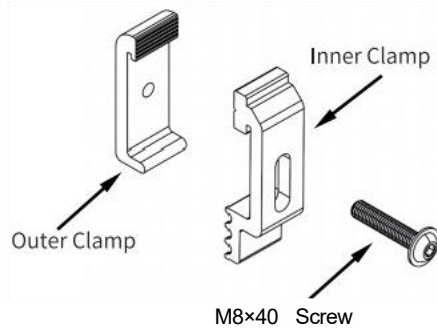
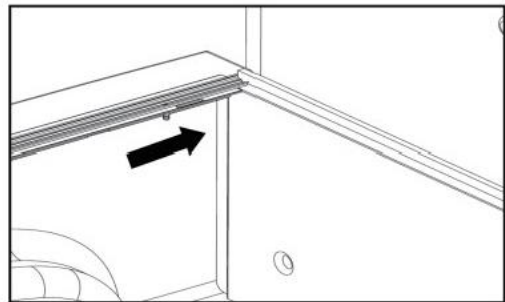
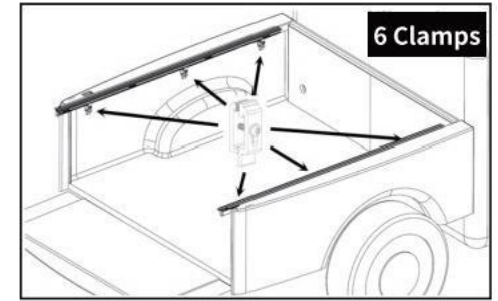
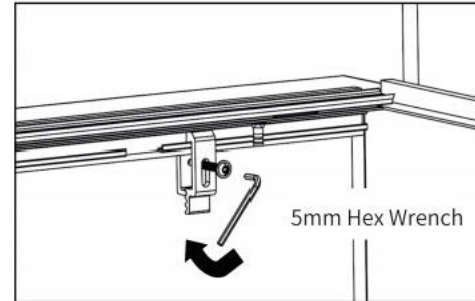
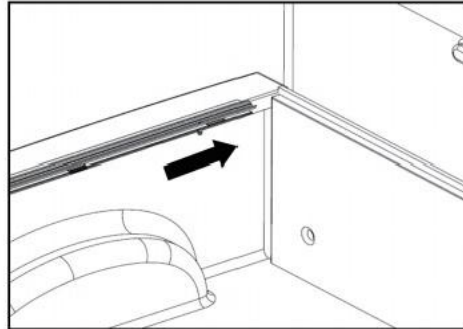
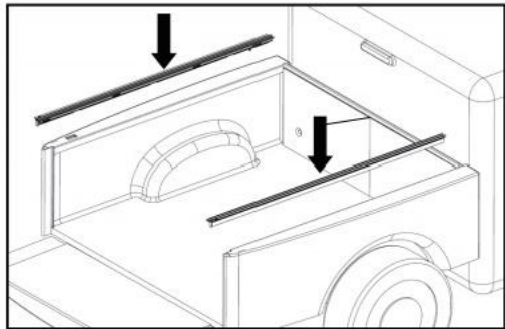

## Step 4:

### For Trucks without Factory Utility Rail:

1. Insert the inner clamps into the side rail.
2. Take the outer clamps to the inner clamps and secure with the M8 screws.
3. Tighten the M8 screws using 5mm hex wrench.

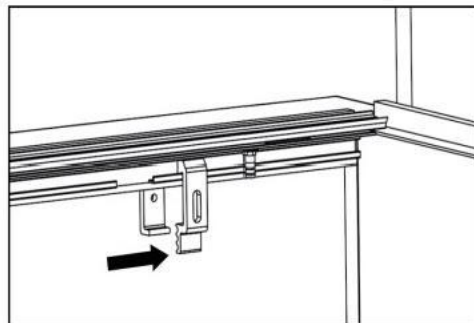
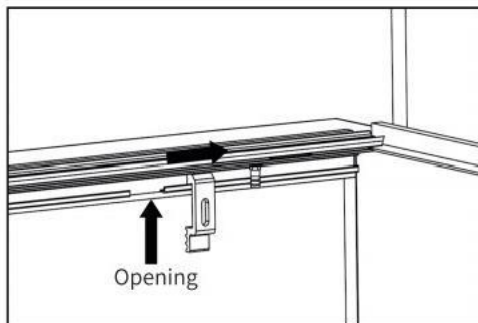

### For Colorado Canyon Trucks Rear Stake Pocket:

1. Insert the rear pocket clamp into the rear end of the side rail.
2. Insert the spacer into the stake pocket opening align with the pocket clamp.
3. Secure the rear pocket clamp with M8 Screw and tighten with 5mm hex wrench.

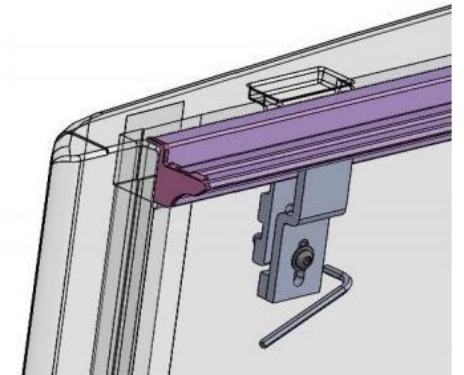
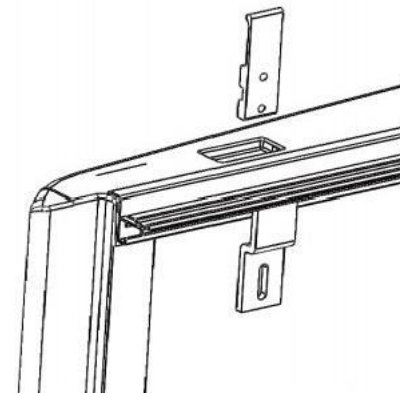

### For Trucks with Factory Utility Rail:

1. Insert the inner clamps into the side rail.
2. Insert the mounting tracks into the utility rail.
3. Align the mounting tracks with the inner clamps and secure with M8 screws.
4. Tighten the M8 screws using 5mm hex wrench.

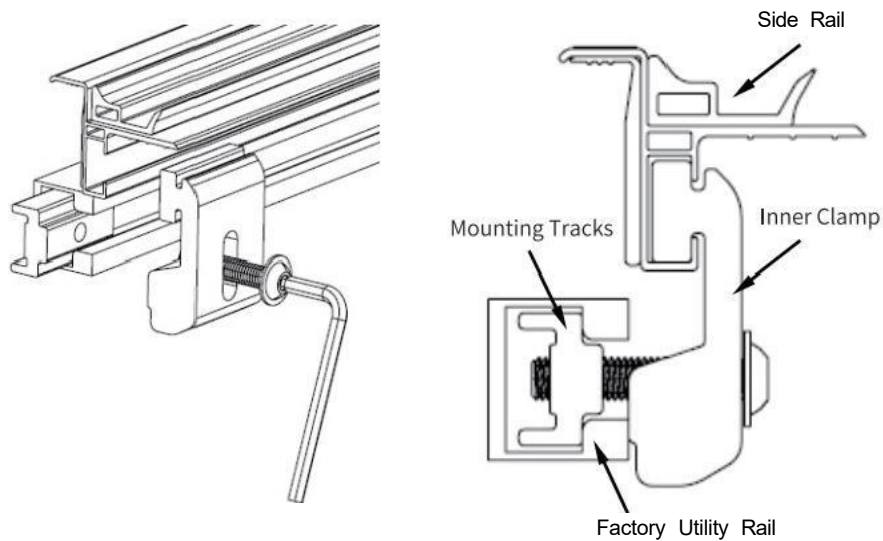

### Step 5:

1. Position the tonneau cover on the truck bed. Ensure the cover's front edge aligns with the front edge of the bulkhead.
2. Flip up the waterproof strip rubber flap to seal front of the bed.  
(Not available on the Ford Maverick)
3. Place the cover in the center, ensure the distance between the latched the side rails is consistent on both side.

**Note:** Multi-people installation is highly recommended.

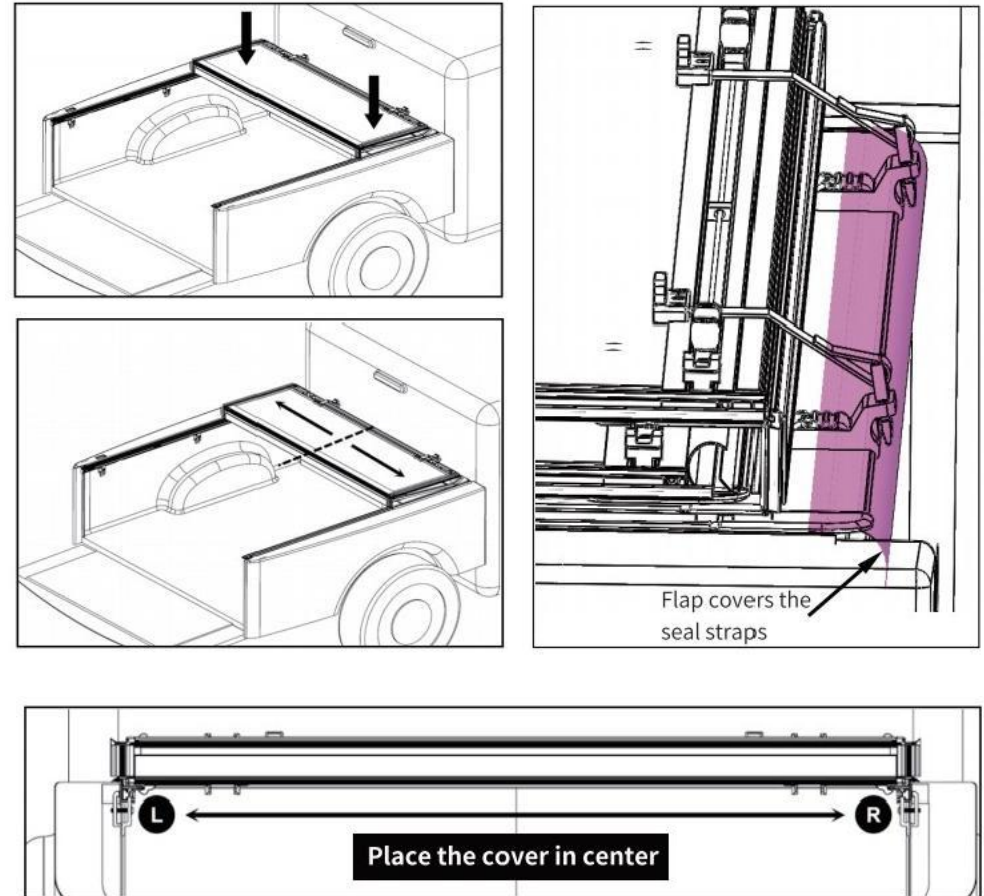

### Step 6:

1. Locate the bed drain openings.
2. Place the drain tube on the fitting on the bed cover rail and through the drain opening to ensure water does not accumulate in the bed.

**Note:** It might be necessary to drill a hole for the drain tube if the drain opening is not available.

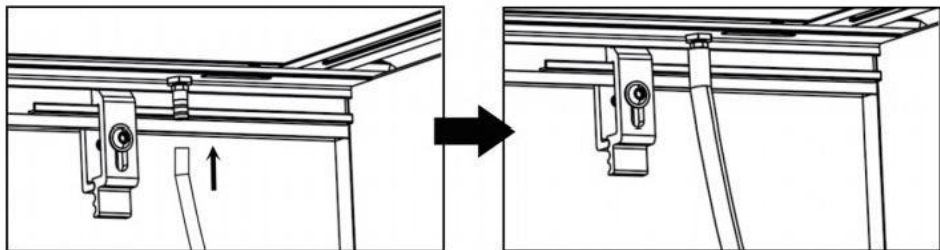

### Step 7:

1. Ensure the cover is pushed up to the front end of the bed.
2. Insert the supplied carriage bolt into the front hole of the cover through the slot in side rail.
3. Secure the tonneau cover with (2)M8 thread knobs,(2)M8 thumb nuts,(2)M8 cap nuts.

**Note:Hand tight ONLY!**

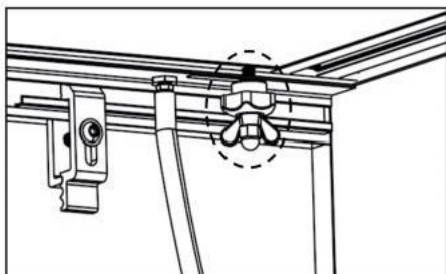
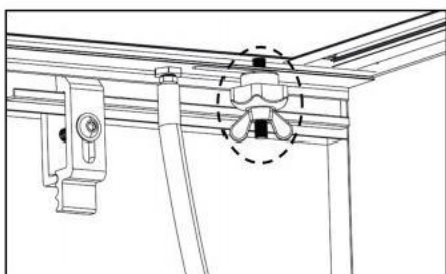
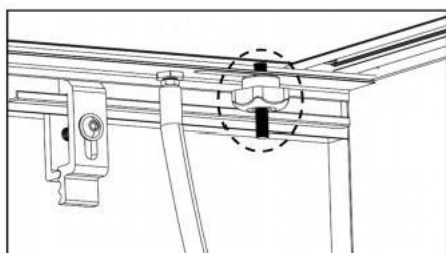
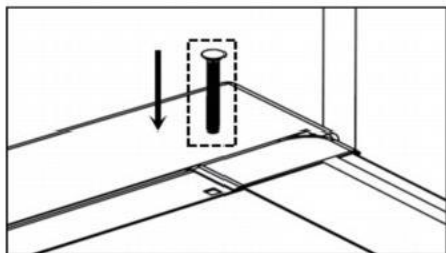

### Step 8:

1. Fully unfold the cover towards rear
2. Close the tailgate.

**Note:**

1. Please check the latch is locked.
2. **DO NOT DRIVE** without locked the cover or the tailgate.

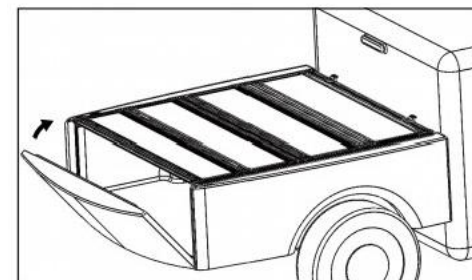
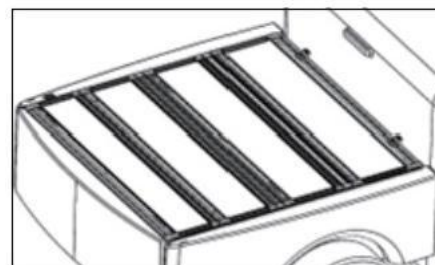
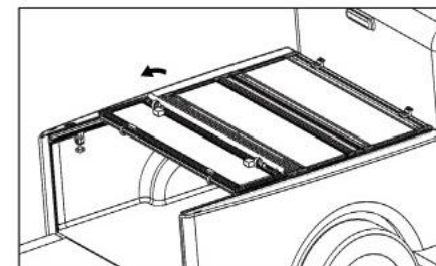
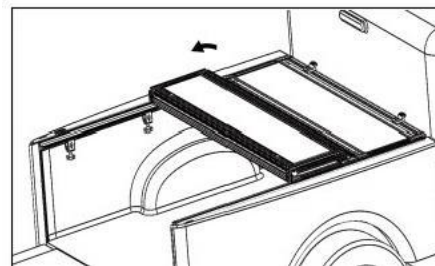

### Step 9:

**Fold up the cover**

1. Pinch the latch lever to unlatch the cover.
2. Carefully fold the cover towards front.
3. Secure the cover with the nylon lock straps.

**Note:DO NOT DRIVE** with cover in unsecured open position.