

Tools Required
13mm Socket
16mm Socket
Ratchet
Torque Wrench

## Before Installation:

Read this instruction carefully before starting installation.

Proper tools will improve the quality of installation and reduce the time required.

If missing parts or any damage found, please take a picture and contact us.

**Professional installation would be highly recommended.**

Periodic check to ensure all mounting hardware remains secure and tight.

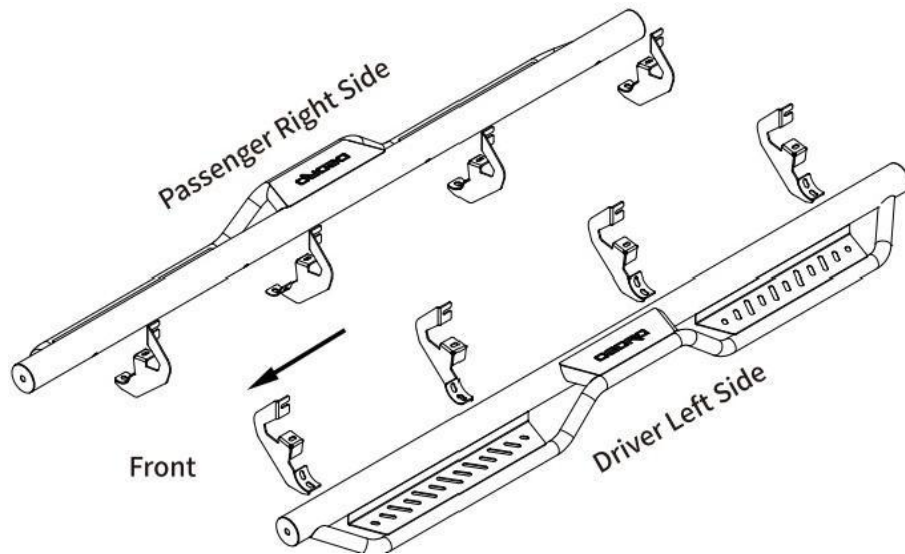

## Step 1:

1. Locate (4) mounting positions each side.
2. Remove factory plugs from mounting positions.
3. Clean the sealant and dirt around mounting positions.

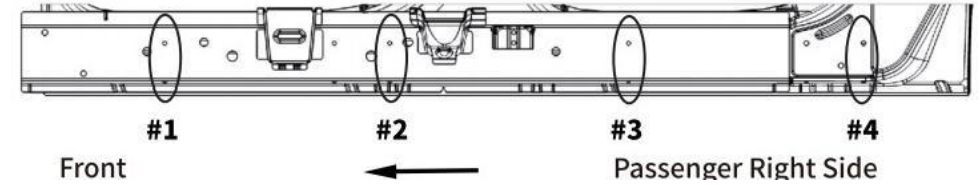

## Step 2:

1. Attach bracket to the rocker panel and secure with (2) M8 hex bolts, (2) M8 flat washers, (2) M8 lock washers.
2. The #2 mounting positions on each side require specific designed bracket.
3. Repeat to install all brackets. Do not fully tighten.

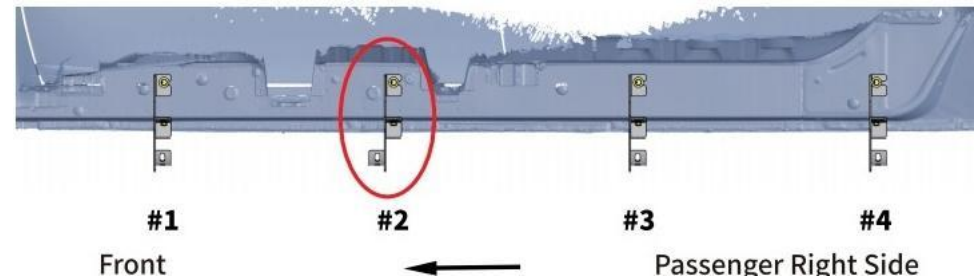
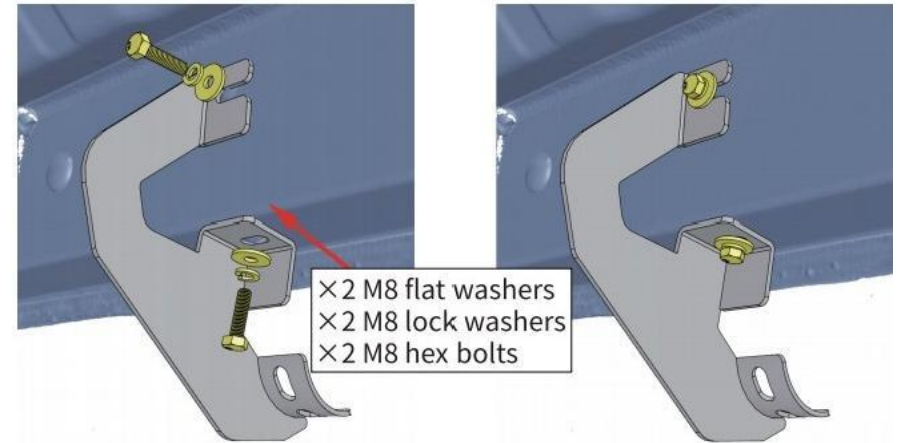

### Step 3:

1. With assistance, lift and attach the step bar to brackets. Secure the step bar on brackets using (8) M10 hex bolts, (8) M10 flat washers, (8) M10 lock washers.

2. Repeat to install the other side step bar.

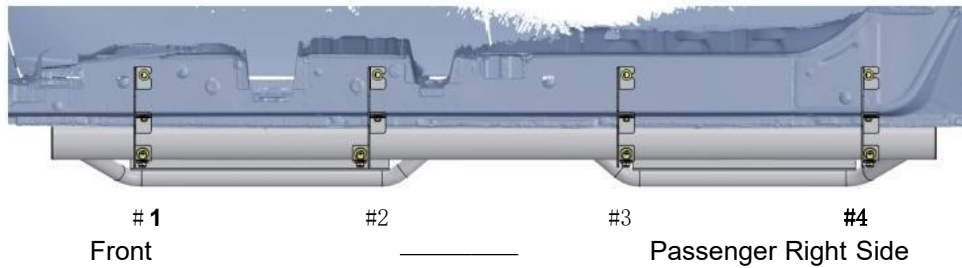
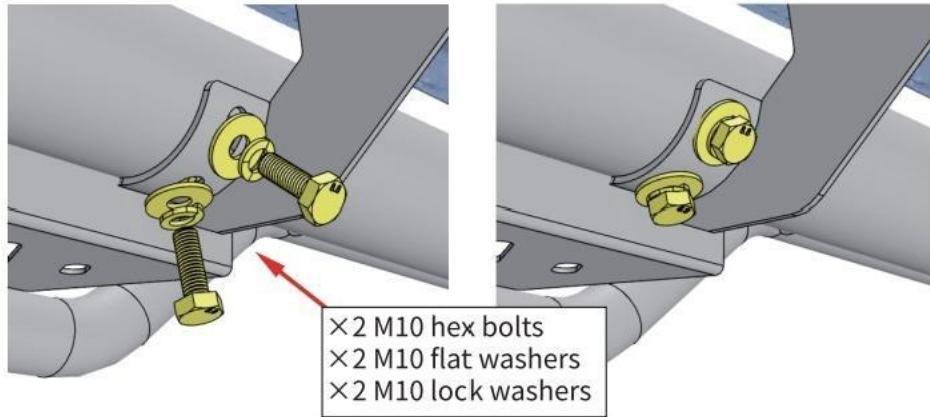

### Step 4:

1. Tighten M8 hex bolts on vehicle with 15 ft.lbs.torque.
2. Adjust the step bar to level and tighten M10 hex bolts with 30 ft.lbs.torque.
3. After the step bar installed, periodic check to ensure all mounting hardware remains secure and tight.

### Part List:

	Qty.	Description
①	×3	Driver Side#1#3#4 Bracket
②	×1	Driver Side#2 Bracket
③	×3	Passenger Side#1#3#4 Bracket
④	×1	Passenger Side#2 Bracket
⑤	×16	M10×30 Hexagon Bolt
⑥	×16	M8×30 Hexagon Bolt
⑦	×16	M10×25 Flat Washer
⑧	×16	M8×24 Flat Washer
⑨	×16	M10 Lock Washer
⑩	×16	M8 Lock Washer

