

Tools Required

13mm, 16mm Socket

13mm, 16mm Wrench

Ratchet

Torque Wrench

Before You Begin

Read instructions thoroughly before installation.

Installation sequence: Mount brackets, position step bars, then tighten all

Prep Work: Clear any paint or debris from the factory studs.

Use proper tools to ensure a correct fit and save time.

Damaged or missing parts? Please take a photo and contact us for support.

Professional installation would be highly recommended.

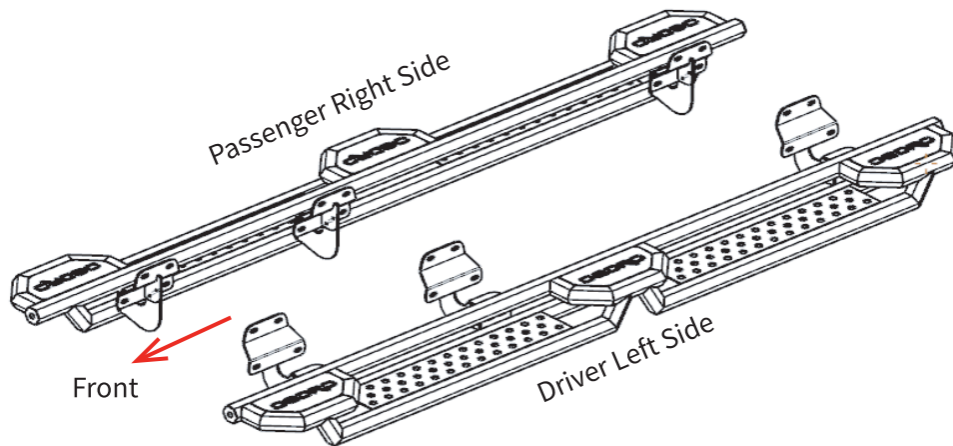

STEP 1:

1. Locate (3) mounting positions each side.
2. Remove the paint buildup on the factory threaded studs.
3. Clean the sealant and dirt around mounting positions.

STEP 2:

1. Attach support arm to the bracket base and secure with (2) M8 hex bolts, (4) M8 flat washers, (2) M8 lock washers, (2) M8 hex nuts.
2. Repeat to assemble all brackets.
Do not fully tighten.

Note: Driver left side bracket as shown.

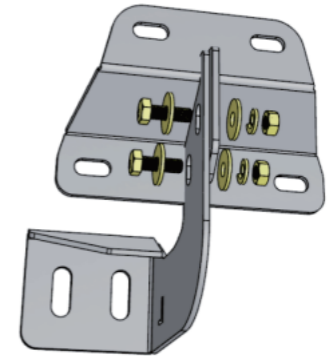

STEP 3:

1. Attach bracket assemble to the inner rocker panel, feed the factory studs through the holes on mounting bracket.
2. Secure the mounting bracket with (3) M8 flat washers, (3) M8 lock washers, (3) M8 hex nuts.
3. Repeat to install all brackets. Do not fully tighten.

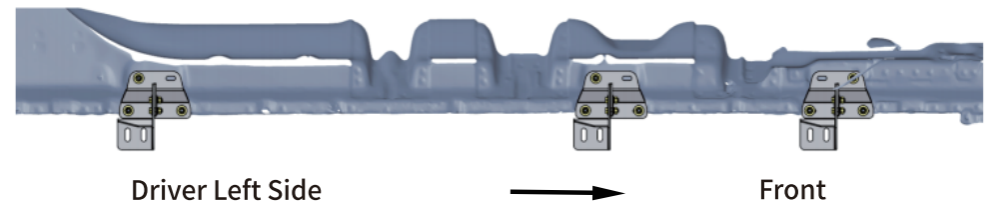
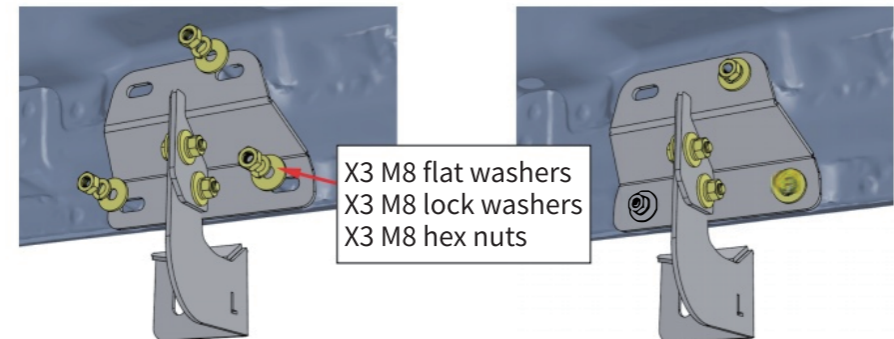

STEP 4:

1. With assistance, lift and attach the step bar to brackets. Secure the step bar on brackets using (6) M10 hex bolts, (12) M10 flat washers, (6) M10 lock washers, (6) M10 hex nuts.
2. Repeat to install the other side step bar.

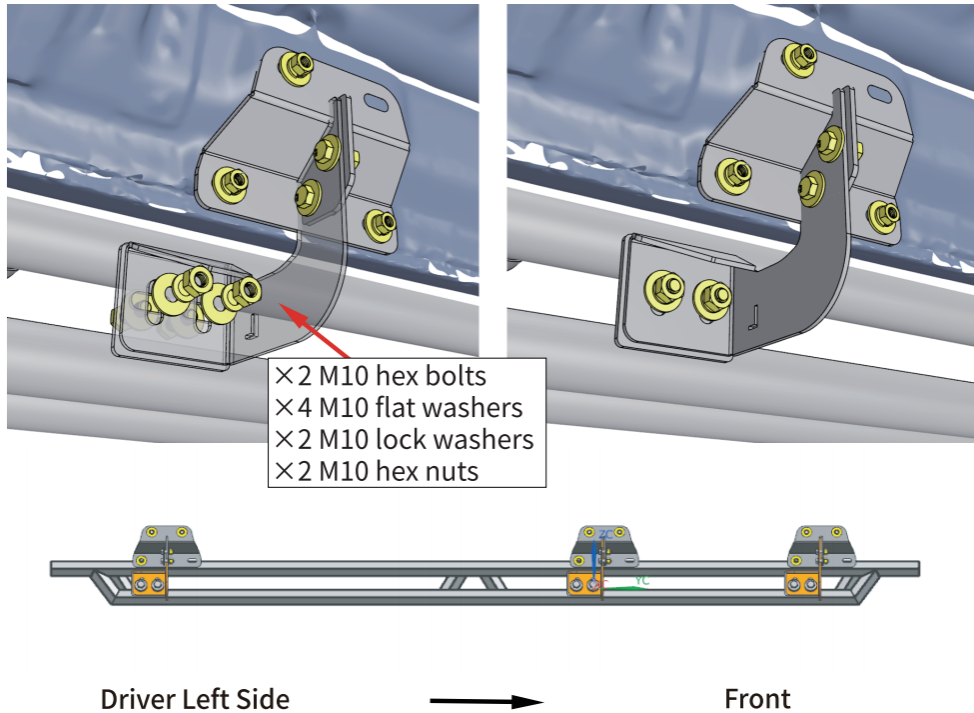

STEP 5:

1. Tighten M8 hex bolts and nuts on vehicle side with 15 ft. lbs. torque.
2. Adjust the step bar to level and tighten M10 hex bolts and nuts with 30 ft. lbs. torque.
3. After the step bar installed, periodic check to ensure all mounting hardware remains secure and tight.

Part List

	Qty.	Description
①	×6	Bracket Mounting Base
②	×3	Driver Side Support Arm (L)
③	×3	Passenger Side Support Arm (R)
④	×12	M10×30 Hexagon Bolt
⑤	×12	M8×25 Hexagon Bolt
⑥	×24	M10×30 Flat Washer
⑦	×42	M8×24 Flat Washer
⑧	×12	M10 Lock Washer
⑨	×30	M8 Lock Washer
⑩	×12	M10 Hexagon Nut
⑪	×30	M8 Hexagon Nut

